

Exclusively from your Caterpillar® dealer

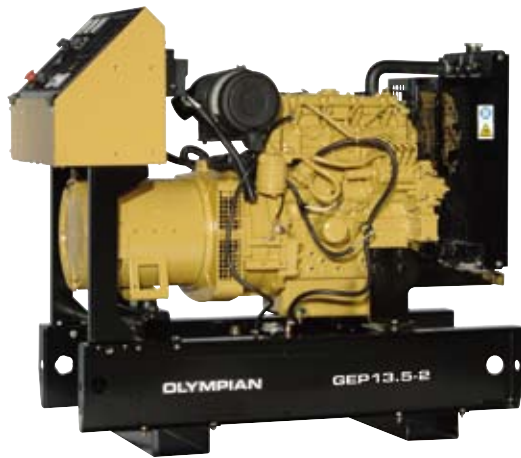

GEP13.5-2 (3-Phase)

50 HZ

STANDBY 13.8 kVA / 11.0 kW

PRIME 12.5 kVA / 10.0 kW

60 HZ

STANDBY 16.2 kVA / 13.0 kW

PRIME 15.0 kVA / 12.0 kW

FEATURES

GENERATING SET

- Complete system designed and built at ISO9001 certified facility
- Factory tested to design specifications at full load conditions
- Fully engineered with a range of options and accessories

ENGINE

- Industrial water cooled diesel engine
- Governor, mechanical
- Electrical system, 12 VDC
- Cartridge type fuel and oil filters
- Air filter
- Battery(ies), rack and cables

ALTERNATOR

- Self excited brushless generator
- Insulation system, class H
- Drip proof alternator air intake (IP23)
- Electrical design in accordance with BS5000 Part 99, IEC60034-1, VDE0530, UTE51100

CONTROL SYSTEM

- PowerWizard 1.0 control panel
- Vibration isolated sheet steel enclosure with hinged lockable door

MOUNTING ARRANGEMENT

- Heavy-duty fabricated steel base with lifting points
- Anti-vibration pads to ensure vibration isolation
- Engine coupled to alternator with flexible disc-coupling
- Baseframe incorporates metal fuel tank, 8 hours running capacity

EXHAUST SYSTEM

- Heavy duty industrial capacity exhaust silencer (approximately 25 dB reduction) supplied loose

COOLING SYSTEM

- Standard ambient temperatures up to 50° C (122° F)
- Fan, fan drive and charging alternator fully guarded
- Antifreeze protection coolant

CIRCUIT BREAKER

- 3-pole miniature circuit breaker (mcb) < 100 amps
- Vibration isolated sheet steel enclosure with removable cover plate
- Outgoing cable stub-up area directly below circuit breaker

AUTOMATIC VOLTAGE REGULATOR

- Voltage regulation $\pm 0.5\%$
- Provides fast recovery from transient load changes

EQUIPMENT FINISH

- All electroplated hardware
- Anticorrosive paint protection
- High gloss polyurethane paint for durability and scuff resistance

QUALITY STANDARDS

- BS4999, BS5000, BS5514, IEC60034, VDE0530

DOCUMENTATION

- Operation and maintenance manuals provided
- Wiring diagrams included

WARRANTY

- All equipment carries full manufacturer's warranty

50 Hz	STANDBY	13.8 kVA	/	11.0 kW
	PRIME	12.5 kVA	/	10.0 kW
60 Hz	STANDBY	16.2 kVA	/	13.0 kW
	PRIME	15.0 kVA	/	12.0 kW

OLYMPIAN™

Exclusively from your Caterpillar® dealer

OPTIONAL EQUIPMENT*

Engine	Electronic governor
Cooling System	Coolant heater
Fuel System	Low fuel level alarm
Silencer System — Open Unit	Overhead mounting kit
Enclosures	CAE sound attenuated canopy CAL sound attenuated canopy High ambient capability
Handling/Trailers	Single point lift Fixed height drawbar 2 wheel trailer Adjustable height drawbar 2 wheel trailer
Controls	LCP0 Series panel LCP1 Series panel PowerWizard 2.0 panel
Remote Annunciator	PowerWizard annunciator
Circuit Breaker	Upgrades from 3-pole to 4-pole breaker 32A CEE Form socket 50 Hz only 63A CEE Form socket 50 Hz only Earth Leakage protection for main output 300 mA, CB trip
Certification	European CE certification 50 Hz only

*Some options may not be available on all models.
Not all options are listed.

Consult your Olympian representative for more information

50 Hz	STANDBY	13.8 kVA	/	11.0 kW
	PRIME	12.5 kVA	/	10.0 kW
60 Hz	STANDBY	16.2 kVA	/	13.0 kW
	PRIME	15.0 kVA	/	12.0 kW

OLYMPIAN™

Exclusively from your Caterpillar® dealer

SPECIFICATIONS



ALTERNATOR

Make Olympian
 Model LL1014H
 Type Self-excited, brushless
 Voltage regulation ±0.5% at steady state from
 no load to full load
 Frequency ±0.8% for constant load from
 no load to full load
 Waveform distortion THD <4%
 Radio interference Compliance with EN61000-6
 Telephone Interference TIF <50, THF <2%
 Overspeed limit 2250 rpm
 Insulation Class H
 Temperature rise Within Class H limits
 Deration Consult factory for available outputs



ENGINE

Manufacturer Perkins
 Model 403C-15
 Type 4-Cycle
 Aspiration Naturally aspirated
 Cylinder configuration In-line 3
 Displacement — L (cu in) 1.5 (91.3)
 Bore/stroke — mm (in) 84/90 (3.3/3.5)
 Compression ratio 22.5:1
 Engine speed — rpm
 50 Hz 1500
 60 Hz 1800

Piston speed — m/sec (ft/sec)
 50 Hz 4.5 (14.8)
 60 Hz 5.4 (17.7)
 Maximum power at rated rpm — kW (hp)
 Standby
 50 Hz 13.5 (18.0)
 60 Hz 16.2 (22.0)
 Prime
 50 Hz 12.2 (16.0)
 60 Hz 14.7 (20.0)
 BMEP — kPa (psi)
 Standby
 50 Hz 722 (105)
 60 Hz 722 (105)
 Prime
 50 Hz 652 (94.6)
 60 Hz 655 (95.0)
 Regenerative power — kW (hp)
 50 Hz 4.5 (6.0)
 60 Hz 5.8 (7.8)
 Governor
 Type Mechanical
 Class ISO 8528 G2

GENERATING SET DIMENSIONS AND WEIGHTS

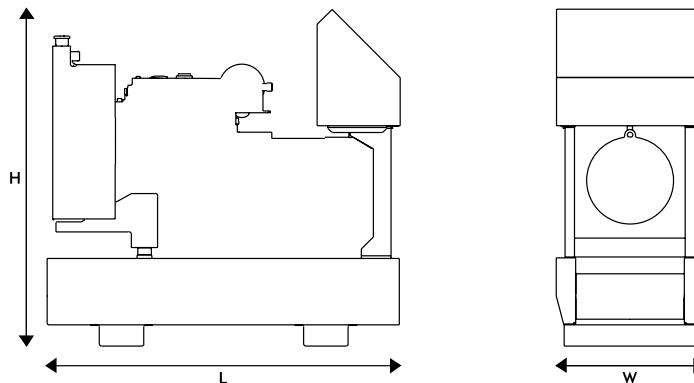

Model	Length mm (in)	Width mm (in)	Height mm (in)	Weight* kg (lb)
GEP13.5-2	1320 (52.0)	552 (21.7)	1258 (50.0)	402 (886)

Note:- General configuration not to be used for installation. See general dimension drawings for detail.

*Includes oil and coolant

Consult your Olympian representative for more information

50 Hz STANDBY 13.8 kVA / 11.0 kW
PRIME 12.5 kVA / 10.0 kW
60 Hz STANDBY 16.2 kVA / 13.0 kW
PRIME 15.0 kVA / 12.0 kW

OLYMPIAN™

Exclusively from your Caterpillar® dealer

GEP13.5-2 (3-Phase)

Generating Set Technical Data		50 Hz		60 Hz	
		Standby	Prime	Standby	Prime
Package Performance Power rating	kVA (kW)	13.8 (11.0)	12.5 (10.0)	16.2 (13.0)	15.0 (12.0)
Lubricating System Type: Oil Oil filter: Spin-on, full flow Oil cooler: Coolant Oil type required: API CH-4/ACEA E5 Total lube system capacity Oil pan capacity	L (U.S. Gal) L (U.S. Gal)	6.0 (1.6) 4.5 (1.2)		6.0 (1.6) 4.5 (1.2)	
Fuel System Fuel Tank Capacity Generating set fuel consumption** 100% load 75% load 50% load	L (U.S. Gal) L/hr (U.S. g/hr) L/hr (U.S. g/hr) L/hr (U.S. g/hr)	45.0 (11.9) 4.1 (1.1) 3.0 (0.8) 2.2 (0.6)	3.7 (1.0) 2.8 (0.7) 2.1 (0.6)	45.0 (11.9) 4.7 (1.2) 3.5 (0.9) 2.5 (0.7)	4.3 (1.1) 3.2 (0.8) 2.4 (0.6)
Engine Electrical System Voltage/ground: 12 vDC/negative Battery charging alternator ampere rating	amps	55		55	
Cooling System Water pump type: Centrifugal Cooling system capacity Maximum coolant static head Coolant flow rate Minimum temperature to engine Temperature rise across engine Heat rejected to coolant at rated power Total heat radiated to room at rated power Radiator fan load	L (U.S. Gal) m H ₂ O (ft H ₂ O) L/hr (U.S. gal/hr) °C (°F) °C (°F) kW (Btu/min) kW (Btu/min) kW (hp)	5.8 (1.5) 3.1 (10.2) 2460 (650) 76 (169) 5.1 (9.2) 12.8 (728) 5.8 (330) 0.2 (0.2)	11.5 (654) 26.0 (918) 5.2 (296)	5.8 (1.5) 3.1 (10.2) 2964 (783) 76 (169) 5.1 (9.2) 15.4 (876) 6.9 (392) 0.3 (0.4)	14.2 (808) 35.0 (1236) 6.4 (364)
Air Requirements Combustion air flow Maximum air cleaner restriction Radiator cooling air External restriction to cooling airflow Generator cooling air	m ³ /min (cfm) kPa (in H ₂ O) m ³ /min (cfm) Pa (in H ₂ O) m ³ /min (cfm)	1.1 (39.0) 6.4 (25.7) 26.0 (918) 125 (0.5) 9.0 (318)	1.1 (39.0) 6.4 (25.7) 26.0 (918) 125 (0.5) 9.0 (318)	1.3 (46.0) 6.4 (25.7) 35.0 (1236) 125 (0.5) 10.8 (381)	1.3 (46.0) 6.4 (25.7) 35.0 (1236) 125 (0.5) 10.8 (381)
Exhaust System Maximum allowable backpressure Exhaust flow at rated power Exhaust temperature at rated power (dry exhaust)	kPa (in Hg) m ³ /min (cfm) °C (°F)	10.2 (3.0) 2.8 (99) 491 (916)	2.6 (92.0) 2.6 (92.0) 446 (834)	10.2 (3.0) 3.5 (124) 504 (938)	3.4 (120) 3.4 (120) 456 (852)
Generating Set Noise Rating* (without attenuation) at 1 m (3.28 ft)	dBA	86.6		N/A	

*dBA levels are for guidance only

**Fuel consumption data at indicated load with diesel fuel with a specific gravity of 0.85 and conforming to BS2869:1998 Class A2.

Alternator Technical Data	50 Hz			60 Hz
	415/240V	400/230V	380/220V	220/127V
Motor Starting Capability: Self Excited (kVA)	25	24	22	24
Full Load Efficiency				
Standby %	82.6	82.6	82.5	84.1
Prime %	83.0	83.3	83.2	84.5
Reactances (per unit)				
Saturated X _d	1.97	2.12	2.35	2.47
X _d	0.15	0.16	0.17	0.18
Reactances are shown X _d	0.073	0.078	0.087	0.091
X _q	0.99	1.06	1.18	1.24
applicable to the X _d	0.107	0.109	0.120	0.127
standby rating X ₂	0.087	0.094	0.104	0.109
X ₀	0.005	0.006	0.006	0.006
Time Constants:	t' _d 25 ms	t'' 2.5 ms	t' _{do} 337 ms	t _a 4 ms

Consult your Olympian representative for more information

5 0 H z S T A N D B Y 1 3 . 8 k V A / 1 1 . 0 k W
 P R I M E 1 2 . 5 k V A / 1 0 . 0 k W
 6 0 H z S T A N D B Y 1 6 . 2 k V A / 1 3 . 0 k W
 P R I M E 1 5 . 0 k V A / 1 2 . 0 k W

OLYMPIAN™

Exclusively from your Caterpillar® dealer

RATINGS AT AVAILABLE VOLTAGES

50 Hz					
Voltage Code	Voltage	Standby		Prime	
		kVA	kW	kVA	kW
VOPT502	415/240	13.8	11.0	12.5	10.0
VOPT503	400/230	13.8	11.0	12.5	10.0
VOPT504	380/220	13.8	11.0	12.5	10.0

60 Hz					
Voltage Code	Voltage	Standby		Prime	
		kVA	kW	kVA	kW
VOPT608	220/127	16.2	13.0	15.0	12.0

Ratings at 27° C (80° F), 152.4 m (500 ft), 60% humidity, 0.8 pf

RATING DEFINITIONS

STANDBY

These ratings are applicable for supplying continuous electrical power (at variable load) in the event of a utility power failure. No overload is permitted on these ratings. When used at standby rating the alternator will be peak continuous rated (as defined in ISO8528-3).

PRIME POWER

These ratings are applicable for supplying continuous power (at variable load) in lieu of commercially purchased power. There is no limitation to the annual hours of operation and this model can supply 10% overload power for 1 hour in 12 hours.

Consult your Olympian representative for more information

50 Hz	STANDBY	13.8 kVA	/	11.0 kW
	PRIME	12.5 kVA	/	10.0 kW
60 Hz	STANDBY	16.2 kVA	/	13.0 kW
	PRIME	15.0 kVA	/	12.0 kW

OLYMPIAN™

Exclusively from your Caterpillar® dealer